

STEP 1

ENSURE UNIT GASKET IS APPLIED PROPERLY.
MOUNT CONVERSION COLLAR TO UNIT AS SHOWN USING THE PROVIDED HARDWARE.
COMPRESS THE UNIT GASKET TO HALF OF ITS THICKNESS.

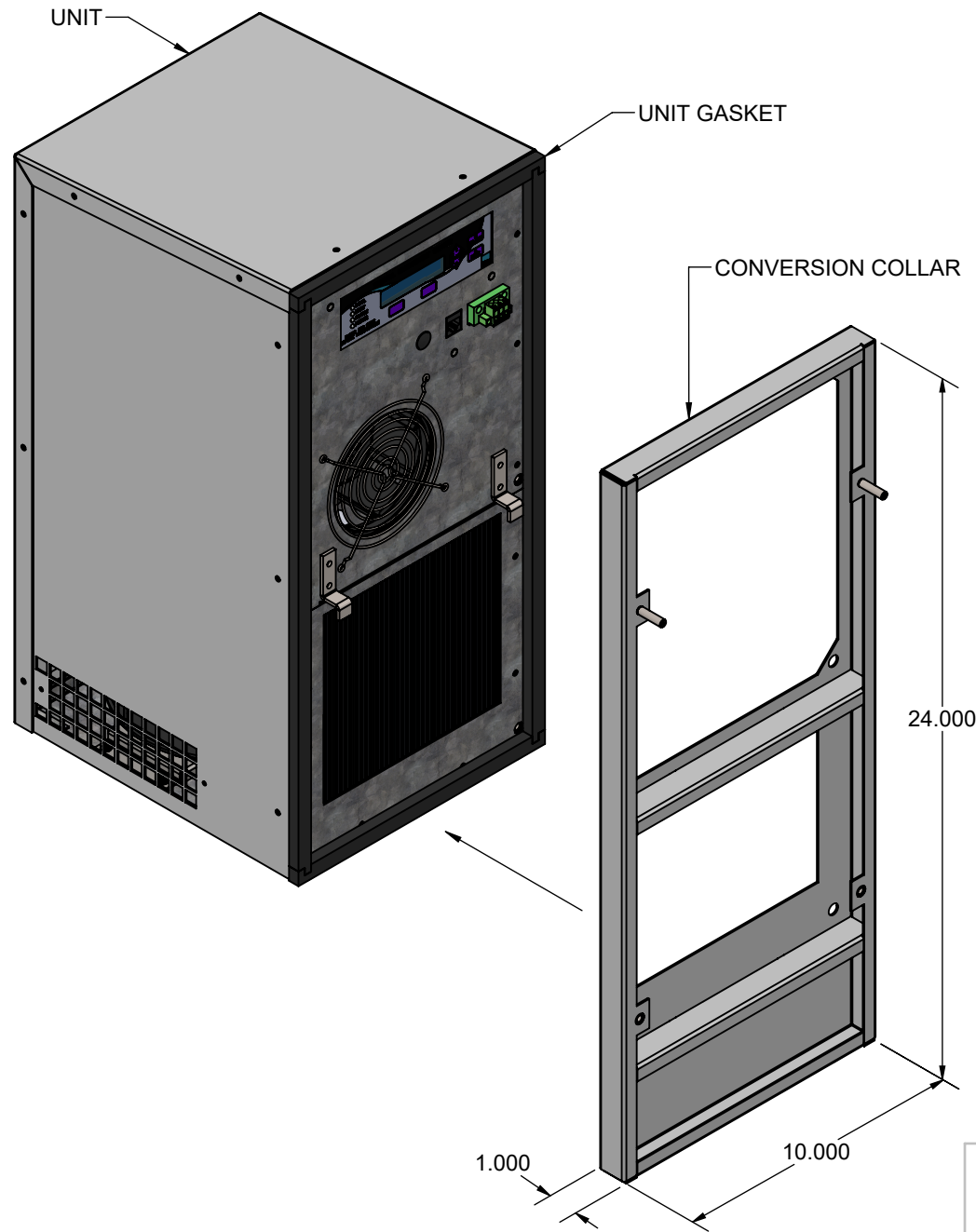

STEP 2

APPLY CONVERSION COLLAR GASKET AS SHOWN.

NOTE: UNIT HIDDEN FOR CLARITY

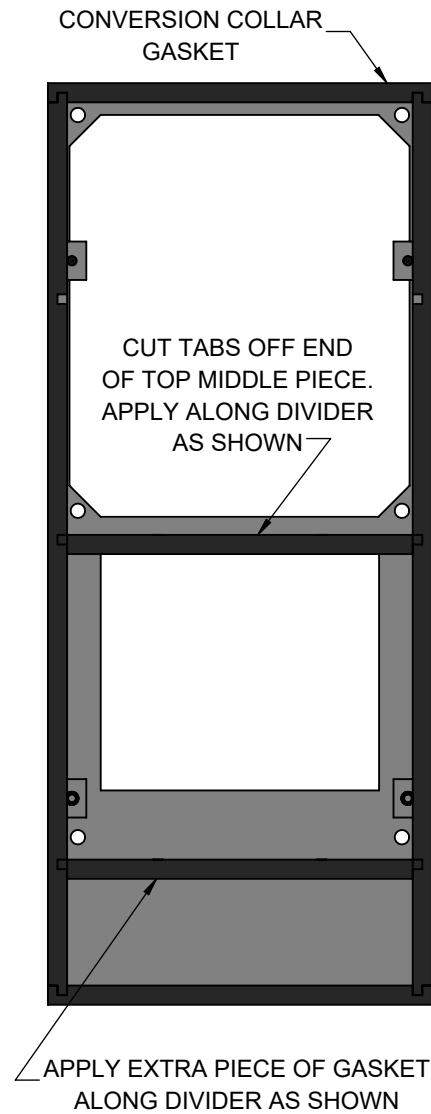

STEP 3

FOR ADDITIONAL CAPACITY SEE OPTIONAL CUTOUT, IQ352950
MOUNT UNIT AND CONVERSION COLLAR TO ENCLOSURE AS SHOWN
USING PROVIDED HARDWARE.
COMPRESS THE CONVERSION COLLAR GASKET TO HALF OF ITS THICKNESS.

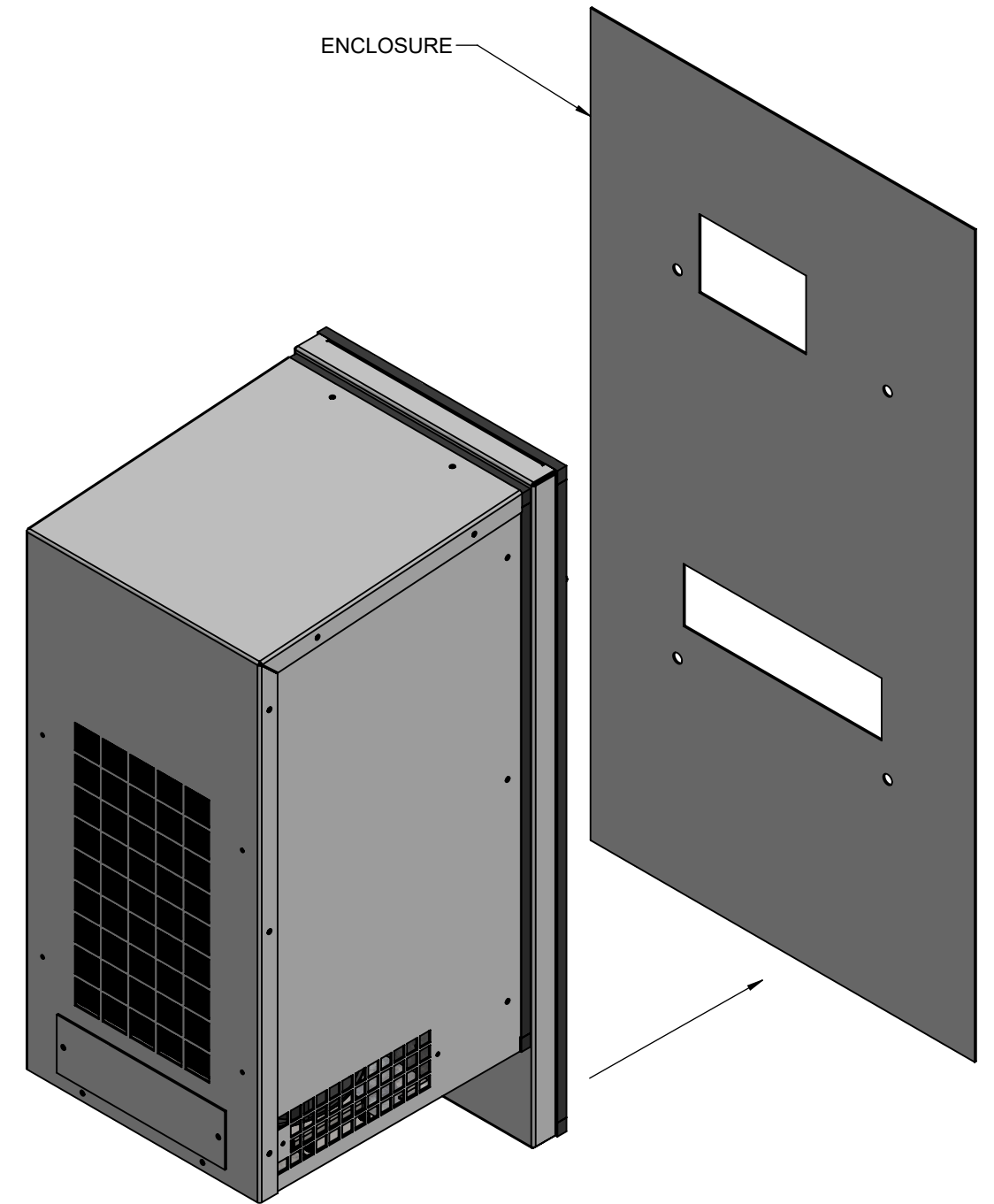

A	INITIAL DRAFT	NAT	9/16/2021				
REV	REVISION	CHG	DATE	APP	DATE	CN #	

ITEM NUMBER	N/A	USED ON	IQ20-2400VXS TO IQ1-2-3000EV AND IQ20-2400VXS TO IQ1-2-3000ECO
MATERIAL	N/A	EST WT:	lbs
DRAWN BY	NAT	DATE	9/16/2021
SCALE	1:5		

UNLESS OTHERWISE SPECIFIED TOLERANCES	
.X	±.060
.XX	±.030
.XXX	±.015
FRACTIONAL	±1/16
ANGULAR	±1/2°
SURFACE FINISH	63
DO NOT SCALE DRAWING DIMENSIONS ARE INCHES	

ICE QUBE, INC.
THIS IS A PROPRIETARY DOCUMENT. DO NOT REPRODUCE OR DISCLOSE WITHOUT THE EXPRESS WRITTEN PERMISSION OF ICE QUBE, INC.

DESCRIPTION
**IQ20-2400VXS TO IQ1-2-3000EV/ECO
CONVERSION COLLAR INSTRUCTIONS**

DRAWING NUMBER
IQ352890

REV
A